



# Leveraging Dynamic Response Pixel Technology to Optimize Inter-scene Dynamic Range

An Aptina™ Technology White Paper

## Introduction

Real-world cameras often encounter both very bright scenes and very dark scenes. To capture these scenes, image sensors are typically optimized for one extreme at the price of degraded performance for the other. The challenge is how to design an image sensor to work optimally in all scene conditions.

For the image sensor within these cameras, this translates into requirements for larger full-well (FW) capacities as well as increased sensitivity. This is true for both the larger pixels heavily used in PCs, gaming, automotive, surveillance, and digital single-lens reflex (DSLR) cameras and the ever-shrinking pixel sizes used in mobile phone applications and digital still cameras (DSCs). However, higher sensitivity could limit FW capacity, the maximum achievable signal-to-noise ratio (SNR), and the total dynamic range (DR) of the sensor.

Pixels greater than 2 microns often have their FW capacity defined by the photodiode's charge holding capacity, rather than the pixel's voltage swing, due to its larger photosensitive area. To increase the charge handling capacity of this pixel, it is common to connect a physical capacitor to the floating diffusion (FD) node. However, this typically results in lower conversion gain (CG). This, in turn, means reduced sensitivity and increased input-referred read noise, thereby compromising low-light sensitivity and reducing the sensor's DR even though the sensor is capable of measuring larger signals.

Many approaches to increasing DR focus on achieving high intra-scene dynamic range. However, these HDR techniques do not improve low-light sensitivity or reduce noise to improve low-light image captures. As a result,

a different approach has emerged to improve inter-scene DR and sensor performance through the addition of a high-sensitivity mode to the sensor's operation. Two modes are combined in one pixel design – low conversion gain (LCG) for large charge handling capacity in bright scenes and a high conversion gain (HCG) mode with increased sensitivity and low read noise for low-light scenes, providing tremendous benefit for DSLR, surveillance, and notebook/PC cameras, as well as automotive imaging systems, where image sensors are expected to capture images/video in extreme low-light conditions without sacrificing the performance in high-light conditions to do so.

## Relationship between Conversion Gain and Full-Well Capacity

To understand the benefit of adding an HCG mode, it is important to discuss the trade-off between CG, the measure of the sensitivity of the charge detection at the FD node in a CMOS image sensor pixel, and FW in a pixel design.

The CG is actually an inverse way of expressing the capacitance of the FD node. Capacitance can be calculated as the ratio of the amount of charge required to change the potential of a node by one volt (see Equation 1), where  $Q$  is charge in Coulombs, and  $V$  is the potential in Volts. This means that, as the capacitance of the FD node increases, the conversion gain and hence, sensitivity of the FD node decreases.

$$C = Q/V$$

Equation 1: Basic formula for capacitance

# Leveraging DR-Pix Technology

Generally, the amount of voltage swing allowed in the pixel is fixed by the overall sensor design. This fixed range of voltage means that CG can have a distinct impact on the sensor's FW. For example, in a typical design, the power supply is fixed at 2.8 V and the analog signal chain has a fixed window of 1 V allowed voltage swing at the input. For example, if 1 V of swing is allowed at the pixel's output and the source follower (SF) gain is 0.8, then the allowed voltage swing at the FD is equal to  $1\text{ V} / 0.8 = 1.25\text{ V}$ .

As shown above, the capacitance of the FD node will determine the amount of charge that can be detected within the fixed voltage operating range. Assuming a 1.25 V FD voltage swing: if a sensor has  $CG = 30\ \mu\text{V}/e$ , then the largest FW capacity achievable will be  $1.25 \cdot 10^6\ \mu\text{V} / 30\ \mu\text{V}/e \sim 42,000$  electrons. Alternatively, if a pixel has a much higher CG equal to  $150\ \mu\text{V}/e$ , then the FW capacity would be limited by the fixed voltage swing:  $1.25 \cdot 10^6\ \mu\text{V} / 150\ \mu\text{V}/e \sim 8,000$  electrons.

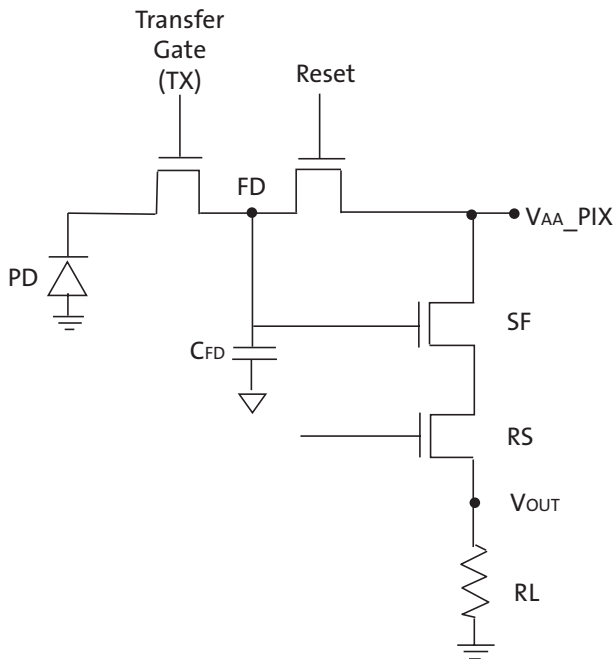

**Figure 1: Pixel schematic.**

Figure 1, a schematic diagram of a standard 4T CMOS image sensor pixel circuit, illustrates the role of CG in the typical pixel design. The definitions of the labels in this pixel schematic are as follows: PD = photodiode, TX = transfer transistor, RST = reset transistor, SF = source follower, RS = row select transistor,  $V_{AA\_PIX}$  = analog pixel power supply voltage,  $V_{OUT}$  = pixel output voltage node, FD = floating diffusion node, and  $C_{FD}$  = capacitance at the FD node –

which is due to both parasitics (pn junction, metal coupling, gate overlap, etc.) and possibly also the addition of a physical capacitor (poly-insulator-poly [PIP], metal-insulator-metal [MIM], metal-oxide-semiconductor [MOS], etc.).

Capacitance is connected in parallel with the FD node, therefore the addition of more capacitance means more charge can be held, but at the expense of reduced sensitivity.

## Importance of both Conversion Gain and Full-Well

Higher CG means higher sensitivity, as one signal electron can be more easily detected. An example curve of signal, in units of mV at the FD node, versus light exposure in units of  $\text{lux} \cdot \text{s}$ , is shown in Figure 2. Responsivity, which is a measure of the sensitivity of an image sensor, is defined as the slope of signal change versus change in exposure.

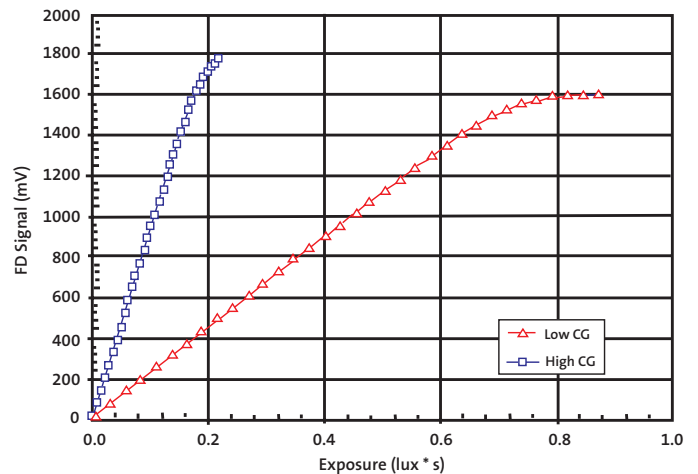

**Figure 2: FD signal in mV as a function of light exposure in  $\text{lux} \cdot \text{s}$  for two sensors with low and high CG, respectively.**

In this example, the high-CG sensor has  $CG=127\ \mu\text{V}/e$  and full-well = 10,500 electrons. The low-CG sensor has  $30.8\ \mu\text{V}/e$  and full-well = 42,000 electrons. In both cases, the overall maximum change in voltage at the FD is nearly equal, at approximately 1.3 V, using only the linear segment of the signal response curve. The high-CG sensor shows a very clear responsivity advantage; however, the trade off is clearly seen in the much lower full-well capacity as the sensor's linear range ends at a much lower exposure.

Higher CG also means that the sensor will realize a reduction in read noise when the system noise is referred back to the FD. It is important to refer the baseline noise of the imaging system back to the signal input, in order to

## Leveraging DR-Pix Technology

compare the amount of read noise to the amount of signal that is being measured.

For example, if the analog signal chain of an image sensor has 100  $\mu\text{V}$  of noise at the input, then this amount of noise can be referred back to the FD by using the SF gain. For example, 100  $\mu\text{V}$  of noise at the pixel's output, divided by SF gain of 0.8, becomes 125  $\mu\text{V}$  of noise when referred to the FD. Now, when divided by CG to convert to noise in units of electrons, this shows that higher CG will result in fewer electrons of noise at the FD. In the example above, the low-CG case saw 125  $\mu\text{V}$  / 30  $\mu\text{V}/\text{e}$  = 4.2 electrons of noise whereas 125  $\mu\text{V}$  / 150  $\mu\text{V}/\text{e}$  = 0.8 electrons of noise was evident in the high-CG case. The higher CG produces not only a larger voltage signal for a given amount of signal electrons, it also makes the noise of the system appear smaller when compared to the measured signal.

Certainly, a balance exists between a sensor's CG and FW. But, how do these parameters affect the max SNR and DR, and what may be done to improve those characteristics?

### How CG and FW Capacity Relate to DR and SNR

Two of the most important parameters of image sensors are the signal-to-noise ratio (SNR) and the dynamic range (DR).

SNR is a very broad way to determine image sensor quality. For a given imaging scene and exposure, a higher SNR value will result better image quality. The  $\text{SNR}_{\text{MAX}}$  (see Equation 2) is a logarithmic ratio of signal electrons at the sensor's saturation exposure ( $N_{\text{MAX}}$ ) to either the total or temporal noise in units of electrons. The result is expressed in units of dB.

$$\text{SNR}_{\text{MAX}} = 20 \cdot \log_{10} (N_{\text{MAX}}/n)$$

#### Equation 2: Formula for signal-to-noise ratio (SNR)

Alternatively, DR is a measure of ratio of the highest and lowest possible signals that can be measured by the sensor (see Equation 3).

$$\text{DR} = 20 \cdot \log_{10} (N_{\text{MAX}}/n_{\text{read}})$$

#### Equation 3: Formula for dynamic range (DR)

The read noise is the lowest measureable signal, and is defined by the base noise level of the sensor's whole signal chain / system. The DR result is also expressed in units of dB.

A larger full-well increases the maximum achievable SNR by increasing  $N_{\text{MAX}}$ . It also increases the overall sensor DR in the

same way. However, by increasing CG, the amount of full-well achievable will be limited.

### Expanding Dynamic Range and Low-Light Performance

Although picture resolution is increasing in today's camera systems, the DR of pixels continues to decrease as pixel sizes shrink, thereby limiting the ability to produce natural photos with both highlights and shadows preserved. As a result, various pixel schemes have been proposed for achieving high dynamic range (HDR), including logarithmic pixels, lateral overflow, frame multi-exposure (ME) and intra-frame multi-exposure (IFME), among others.

These methods of achieving HDR are aimed at achieving high intra-scene DR, which means that dark and bright areas within one scene can be properly exposed. This is commonly achieved either by combining multiple exposure times or frame captures into one image using the multi-frame approach (example signal response shown in Figure 3) [1,2], or by reducing the pixels' responsivity at higher exposures using a nonlinear signal approach (example signal responses in Figure 4).

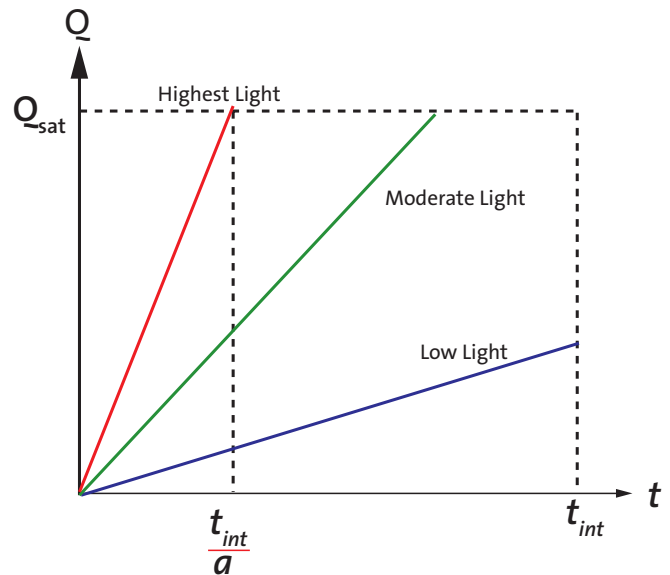
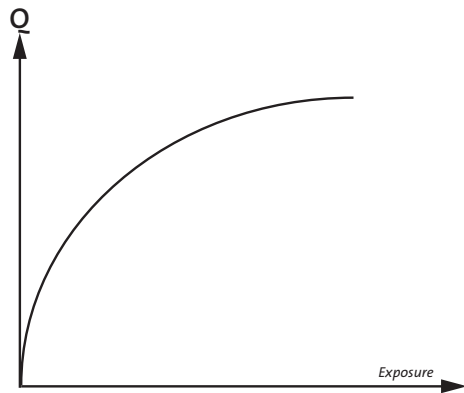

Figure 3: Plot of signal response from high, medium, and low light portions of a scene. ME approaches combine two or more signal responses at different exposure times into one image.

## Leveraging DR-Pix Technology



**Figure 4: Nonlinear signal response vs. exposure curve for an example logarithmic image sensor.**

These techniques can typically achieve very high DR of >100 dB within one image, which is very useful in many applications, such as a surveillance camera properly exposing a criminal's face while sunlight or glare is dominating the rest of the scene or an automotive sign recognition system, which must read sign or road details in the face of headlights or sunlight.

High intra-scene DR has some drawbacks as well. Non-linear pixels may have poor color reproduction and low-light sensitivity, as well as higher fixed pattern noise (FPN). ME techniques not only require extra memory and post processing, but they can have reduced SNR near exposure transition points and motion artifacts caused by exposures captured in a time sequence, thus requiring extra motion compensation and very high frame rates to be useful in video applications.

But, most importantly, what these HDR techniques do not do is improve low-light sensitivity or reduce noise to improve low-light image captures. Applications such as high-end DSLR and mirrorless DSLR cameras require a large FW, responsivity for achieving low ISO-speed conditions and very low noise for high ISO-speed settings used in low-light conditions.

### Dynamic Response Pixel Technology

As a result, a different approach, while not a competitor to HDR technologies, has emerged. This technique, focused on inter-scene DR, adds a separate high sensitivity mode to a pixel that already has a large charge handling capacity.

This approach, called dynamic response pixel technology by Aptina, or Aptina™ DR-Pix™ technology, entails controlled switching on and off of a capacitor connected to the pixel's FD node (Figure 5). To perform this switching, one transistor, called the dual conversion gain (DCG) switch, is added to the

pixel.

When imaging in high light conditions, the DCG switch is turned on, connecting the physical capacitor to the FD node. In this way, the large capacitance of the FD node is used to enable an LCG mode, which can handle a large amount of signal charge.

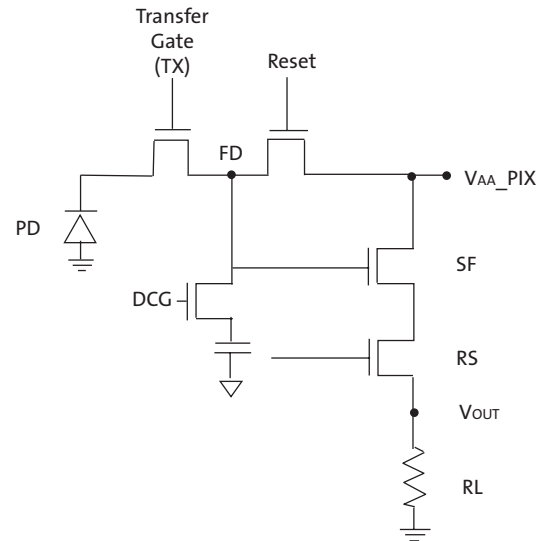

**Figure 5: Schematic diagram of Aptina's DR-Pix technology.**

In low-light conditions, the DCG signal is turned off, disconnecting the cap from the FD, and enabling an HCG mode, which can be used as an extra analog gain, inside the pixel. In this case, the FD capacitance is only due to the parasitic capacitance of the FD's pn junction diffusion and metal coupling, which is much smaller than that due to the physical cap structure. The much lower FD capacitance results in much higher conversion gain, higher sensitivity, and reduced read noise, at the expense of lower maximum charge handling capacity.

This scheme requires an added transistor and capacitor in the pixel layout, which can eat up real estate that could otherwise be utilized to increase the photodiode size. It also adds metal-line routing for the DCG signal control, which reduces the size of the aperture above the photodiode. These drawbacks create extra challenges as pixels shrink beyond the sub-2 micron mark. Also, this scheme is most useful when the photodiode (PD) size is large enough to be the defining factor for the FW capacity. When the amount of charge held in the PD is so large that it cannot be measured within the pixel's allowed voltage swing, then extra

## Leveraging DR-Pix Technology

capacitance must be added to the FD in order to measure all of the PD's charge. In this case the DCG feature can be added to the pixel design to add the HCG mode for improved low-light performance.

This scheme allows very high inter-scene DR by providing high sensitivity and low read noise for dark scenes, and large charge handling capacity for well-lit scenes -- all inside of one pixel design. In this approach, the DR of one scene is not increased, but the range of illumination over which the sensor may be used is extended at the low-light end by the addition of the HCG mode. For DSLR applications, this means shooting high ISO without the need for unnatural-looking flash. For surveillance and PC-camera applications that must capture video often in dimly lit conditions, this is also a tremendous benefit.

The following images are taken from Aptina's MT9H004 sensor, which is an APS-C sized sensor that employs Aptina DR-Pix technology for high-end DSLR and mirrorless camera applications. The sensor has a max SNR around 47 dB, and inter-scene DR equal to 82.9 dB due to the low read noise of the HCG mode. In comparison, without the HCG mode of operation, the sensor's DR would be limited to 69 dB of intra-scene DR in the LCG mode.

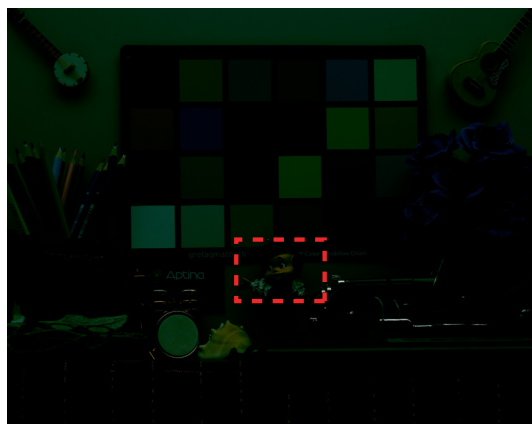

Figure 6: Aptina MT9H004 sensor with Aptina DR-Pix technology, 144 lux daylight illumination, 125 ms exposure, in LCG mode.

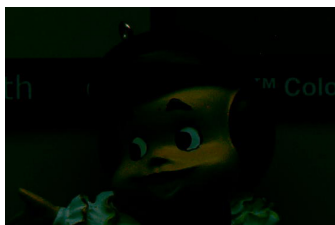

Figure 7: Zoomed-in portion of low conversion gain image taken in low-light resulting in underexposure.

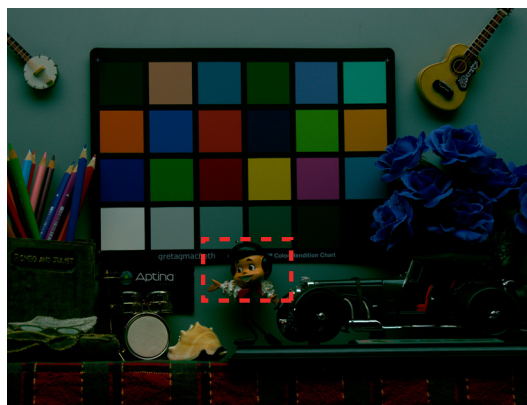

Figure 8: Aptina's MT9H004 sensor with Aptina DR-Pix technology with the HCG mode enabled, resulting in higher sensitivity and lower noise. Seen in 144 lux daylight illumination and 125 ms exposure.



Figure 9: Zoomed-in portion of the HCG image taken at low light, showing the increased sensitivity and low noise.

When compared with the underexposed images seen in Figures 6 and 7, the improved sensitivity and low noise of the HCG mode under low-light conditions is evident in Figures 8 and 9.



Figure 10: Overexposed scene using HCG in a 2,430 lux daylight illumination scene with 125 ms of exposure time.

# Leveraging DR-Pix Technology

In bright scenes, large pixel capacity is required. Figures 10 and 11 display the effect of an overexposed scene caused by the low charge handling capacity of the HCG mode, which leads to washed out details in the image.

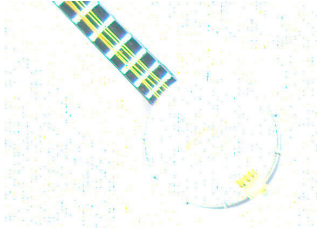
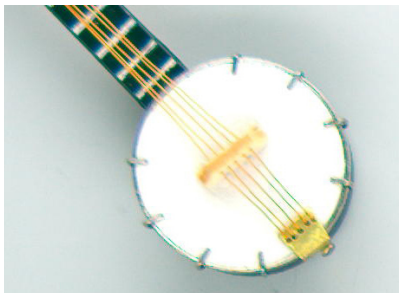

**Figure 11: Zoomed-in portion of an overexposed image, caused by HCG in a brightly lit scene.**

Figures 12 and 13 show the benefit of properly exposing this scene with Aptina DR-Pix technology LCG mode enabled.



**Figure 12: Properly exposed bright light scene, 2,430 lux daylight illuminant, 125ms, enabled by the LCG mode of Aptina's MT9H004 sensor with Aptina DR-Pix technology.**

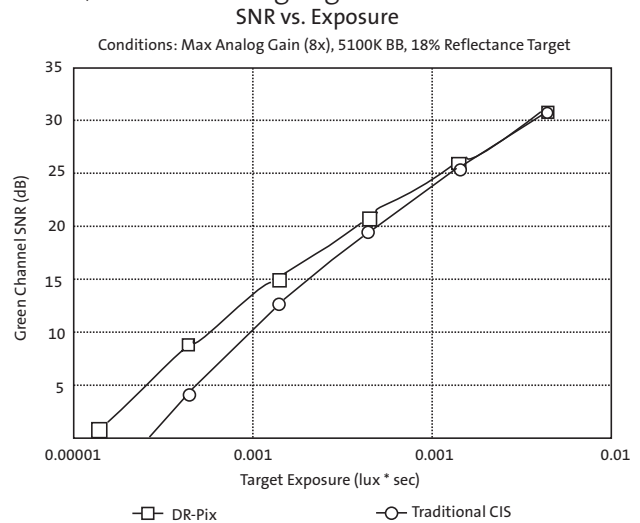

**Figure 13: Zoomed-in portion of a properly exposed brightly lit scene, which retains detail in bright areas due to large signal handling capacity.**

To illustrate the benefit for camera applications, the sensor's measured parameters (quantum efficiency, full-well, read noise, and conversion gain) are used to calculate SNR. The illuminant spectrum used for the calculations is a 5100K black body source.

The plot of Figure 14 shows the green channel SNR, in units

of dB, as a function of exposure. When compared to a traditional CMOS image sensor (with only low-CG), this architecture shows an up to 5 dB increase in SNR under low-light conditions, when high ISO-speed would be utilized, by enabling the increased sensitivity and reduced read noise of the HCG mode. In fact, the benefit of the HCG mode can begin to be observed even at moderate light levels. Higher SNR can be obtained in low-light conditions, while the SNR, equal to that of a traditional sensor, is retained at high-light conditions.

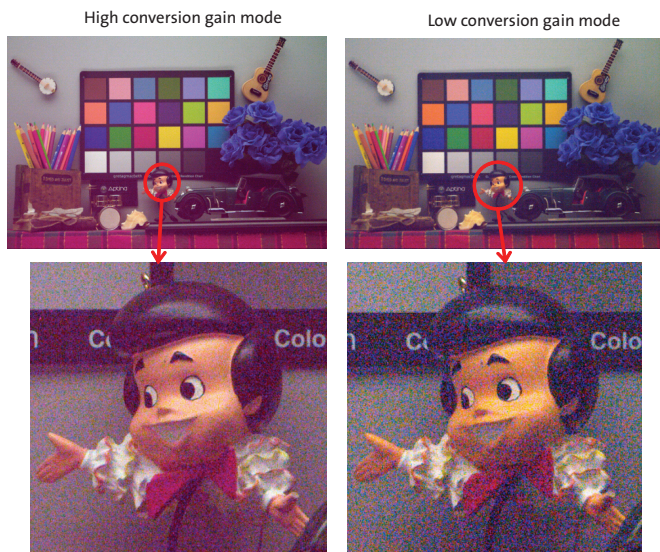

**Figure 14: The Aptina DR-Pix technology approach results in much higher SNR at low-light conditions, compared to a traditional pixel with only LCG.**

To relate this to real world camera operation, Figures 15 and 16 show images taken from Aptina's 16 megapixel DSLR (MT9H004) sensor with Aptina DR-Pix technology at ISO speeds of 100 and 12800.



**Figure 15: ISO 100 image captured by Aptina's 16 megapixel DSLR sensor**



**Figure 16: ISO 12800 image captured by Aptina's 16 megapixel DSLR sensor showing 5 dB increase in SNR in HCG mode**

### Conclusion

For many applications, including surveillance cameras, automotive sign recognition systems, or DSLR cameras, the need to capture very bright scenes and very dark scenes is a reality. To capture these scenes, image sensors are typically optimized for one extreme at the price of degraded performance for the other. In reality, these imaging applications require large FW capacities as well as increased sensitivity. However, higher sensitivity could limit full-well capacity, the maximum achievable SNR, and the total sensor DR.

Several approaches have been introduced for implementing intra-scene HDR, but they do nothing to improve low-light sensitivity or reduce noise. Another approach, offered by Aptina targets inter-scene DR. Called Aptina DR-Pix technology, the technique combines two modes of operation in one pixel design – low CG for large charge handling capacity in bright scenes and a high CG mode with increased sensitivity and low read noise for low-light scenes, providing tremendous benefit for mirrorless and high-end DSLR, surveillance, and notebook/PC cameras, as well as automotive imaging systems, where images/video must be captured in extreme low-light conditions without sacrificing performance in high-light conditions.

### References

1. M. Mase, S. Kawahito, M. Sasaki, S. Wakamori, "A Wide Dynamic Range CMOS Image Sensor with Multiple Exposure-Time Signal Outputs and 12-bit Column-Parallel Cyclic A/D Converters," IEEE J. of Solid State Circuits, Vol. 40, NO. 12, pp 2787-2795, December 2005.
2. M. Sasaki, M. Mase, S. Kawahito, S. Wakamori, "A Wide Dynamic Range CMOS Image Sensor with Multiple Short-Time Exposures," Proc. IEEE Sensors, Vlnna, Oct2004, pp. 967-972.
3. S. Kavadis, B. Dierickx, D. Scheffer, A. Alaets, D. Uwaerts, and J. Bogaerts, "A Logarithmic Response CMOS Image Sensor with On-Chip Calibration," IEEE J. Solid-State Circuits, vol. 32, Feb 1997, pp. 1146-1152.
4. M. Loose, K. Meier, J. Schemmel, "A Self-Calibrating Single Chip CMOS Camera with Logarithmic Response," IEEE J. Solid-State Circuits, vol. 36, April 2003, pp. 586-596.

### About Aptina

Aptina is a global provider of CMOS imaging solutions with a growing portfolio of products that can be found in all leading mobile phone and notebook computer brands as well as a wide range of products for digital and video cameras, surveillance, medical, automotive and industrial applications, video conferencing, barcode scanners, toys, and gaming. Aptina enables Imaging Everywhere™ and continually drives innovation in the market as seen with the introduction of the first 14MP CMOS image sensor for point-and-shoot and hybrid cameras (MT9F001), and the industry's first 5MP SOC with 1/4" format (MT9P111). Privately held Aptina's investors include Riverwood Capital, TPG Capital and Micron Technology. For additional information on Aptina and news on technology webcasts visit [www.aplina.com](http://www.aplina.com). Subscribe to the latest news from Aptina by copying the [Aptina RSS feed](#) into your favorite RSS reader.

©2010 Aptina Imaging Corporation. All rights reserved. Information is subject to change without notice. Aptina, the Aptina logo, A-Pix, DR-Pix, and Imaging Everywhere, are trademarks of Aptina Imaging Corporation.